

THE INFORMATION DISCLOSED ON THIS DRAWING IS PROPRIETARY AND SHALL NOT BE DISCLOSED, USED, OR DUPLICATED FOR PROCUREMENT OR MANUFACTURING PURPOSES WITHOUT THE EXPRESS WRITTEN CONSENT OF AEROQUIP CORPORATION. [DFARS 252.227-7013(d)(2)]

REVISIONS			
REV	DESCRIPTION	DATE	APPROVED
A	(1) WAS 93.5 REF [3.68] (2) WAS 53.3 REF [2.10] (3) WAS 8.1 REF [.32]	2001-09-10 DK	EN-F21939 DP-1299

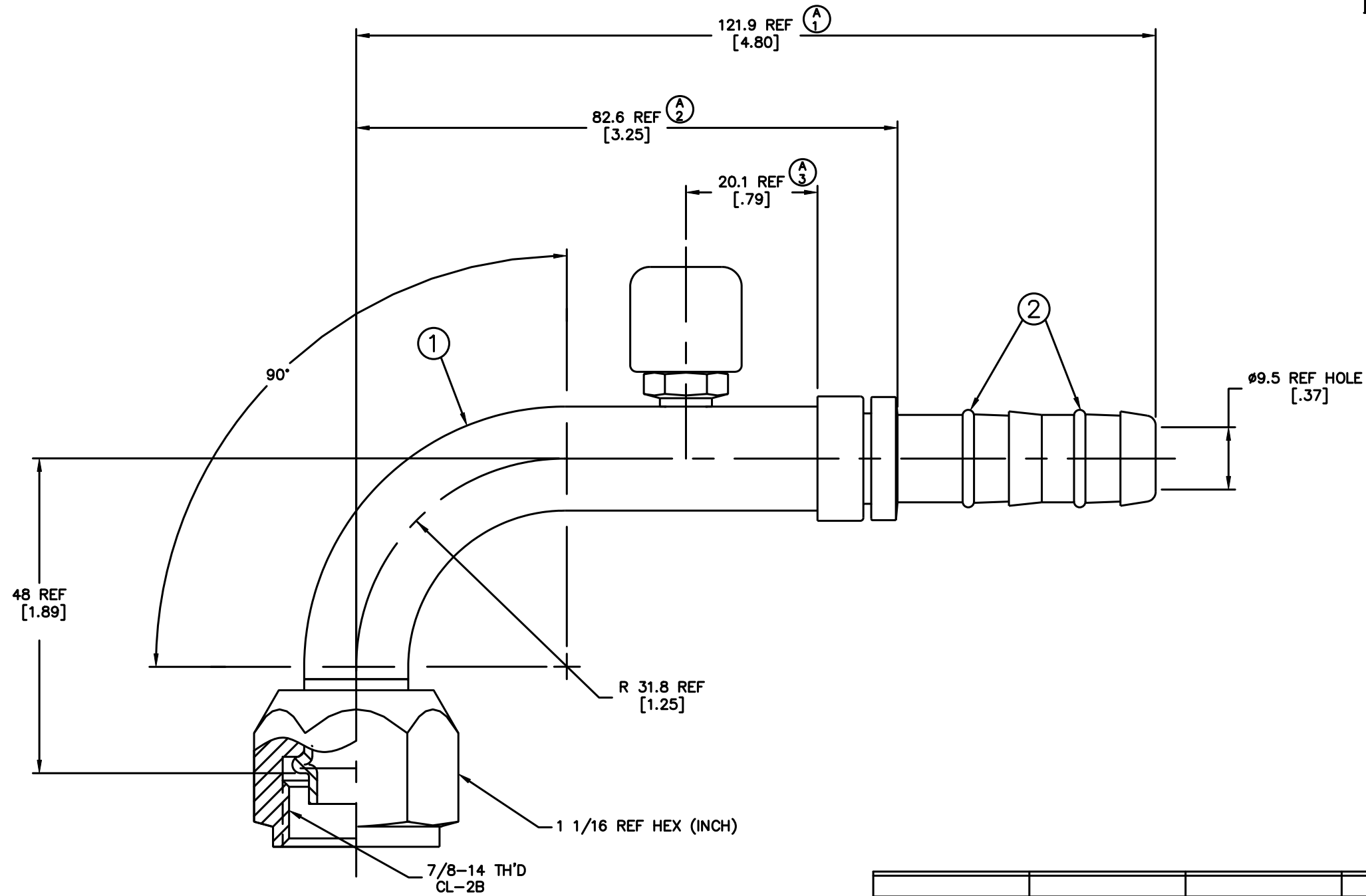

METRIC

FJ3163-01-1010S	FJ2163-01-1010S	1F40106-10			
AEROQUIP PART NUMBER	(1) NIPPLE ASSEMBLY	(2) O'RING (2 REQ'D)			

LIST OF MATERIALS

ITEM NO.	MATERIAL
1	STEEL
2	HNBR

DRAWN
R. KELLY
CHECKED
R.D. WEBB
APPROVED
R.D. GARRETT
RELEASE DATE
2000-07-24
EN-F20160
DP-1256
THIRD ANGLE PROJECTION
ITEM TYPE:

Aeroquip AEROQUIP CORPORATION
Industrial Products Group
Mourree, Ohio, U.S.A.

DRAWING TITLE
FITTING ASSEMBLY
90° FEMALE O'RING PILOT (SHORT), WITH
R12 CHARGE PORT, GH134 HOSE

SIZE A2	DRAWING NUMBER FJ3163-01-1010S	REV A
SCALE 2/1	DIST U	CAGE CODE 01276
		SHEET

2. DIMENSIONS ARE IN MILLIMETERS [INCHES].
1. PROCESS AS FOLLOWS:
(a) LUBRICATE O'RINGS AND ASSEMBLE TO NIPPLE AS SHOWN.

DWG. NO. FJ3163-01-1010S REV. A