

REV	DESCRIPTION	BY	CHK	DATE	ECN / MPS
A	ENGINEERING RELEASE	NWS	BMS	5-28-08	0018094
B	(IC)WAS M12 X 2.5-6H	MKS	MKS	4/10/09	0016471
C	REVISED	AB	KBK	06/26/18	MI08183

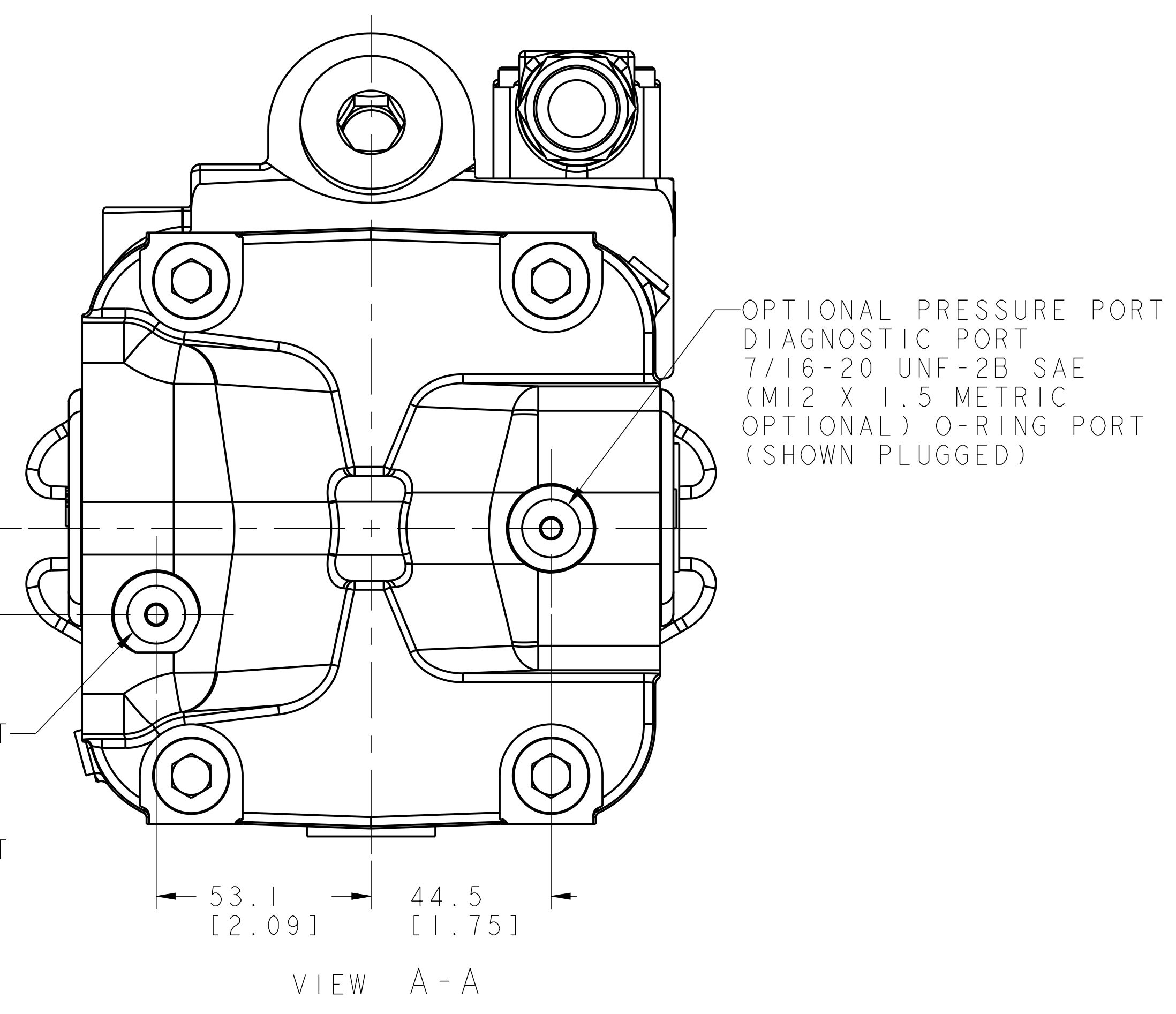
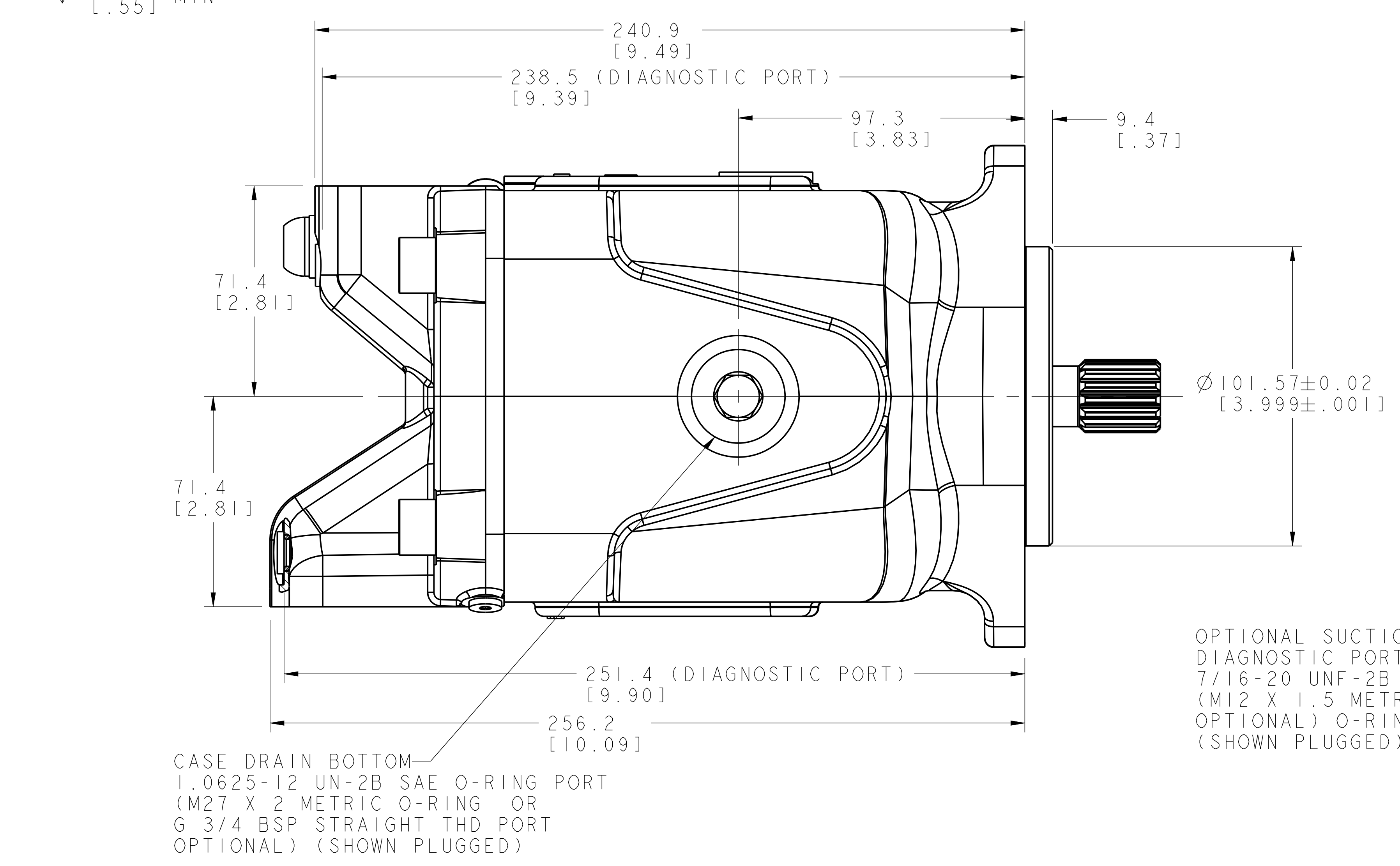
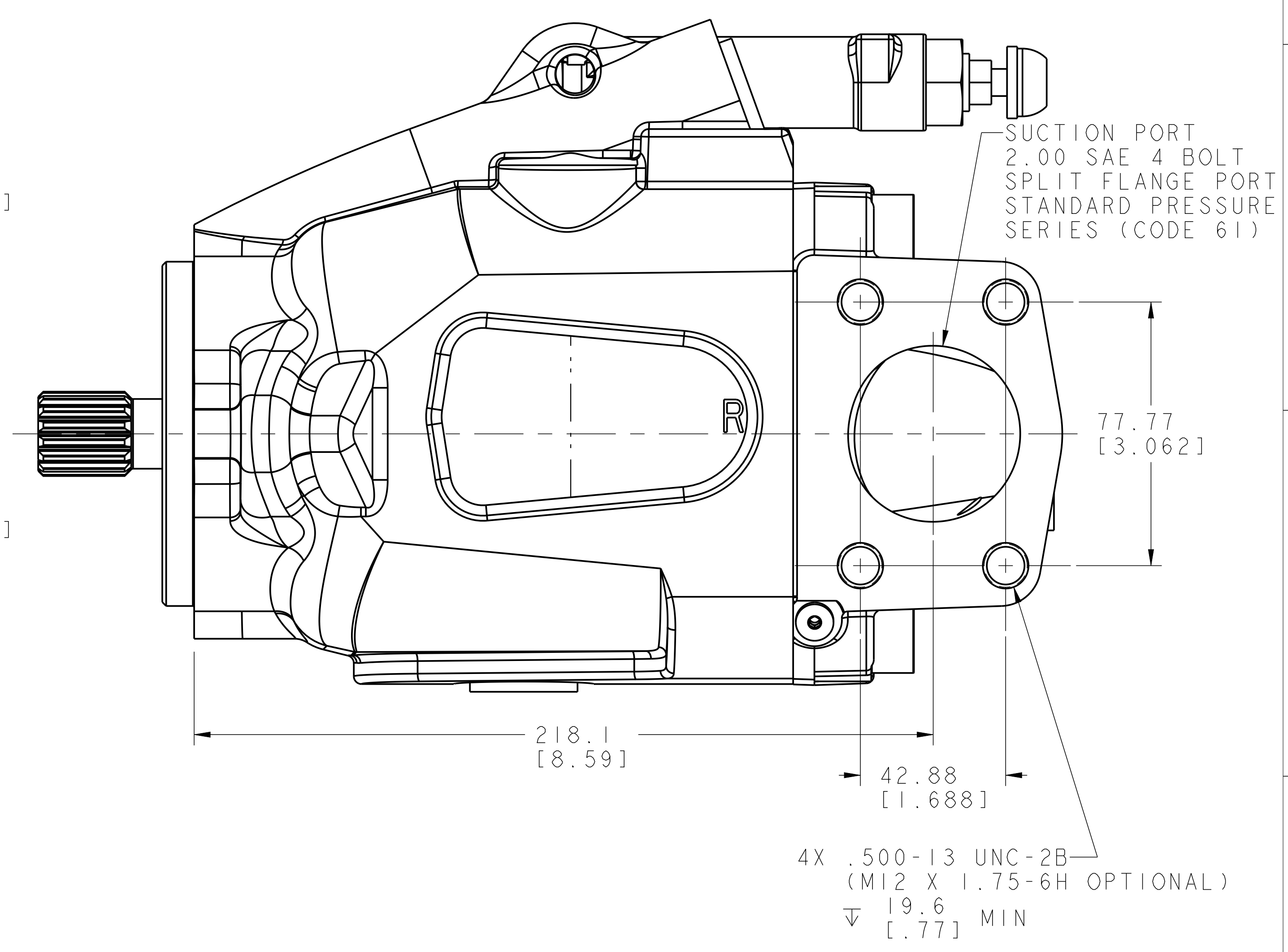
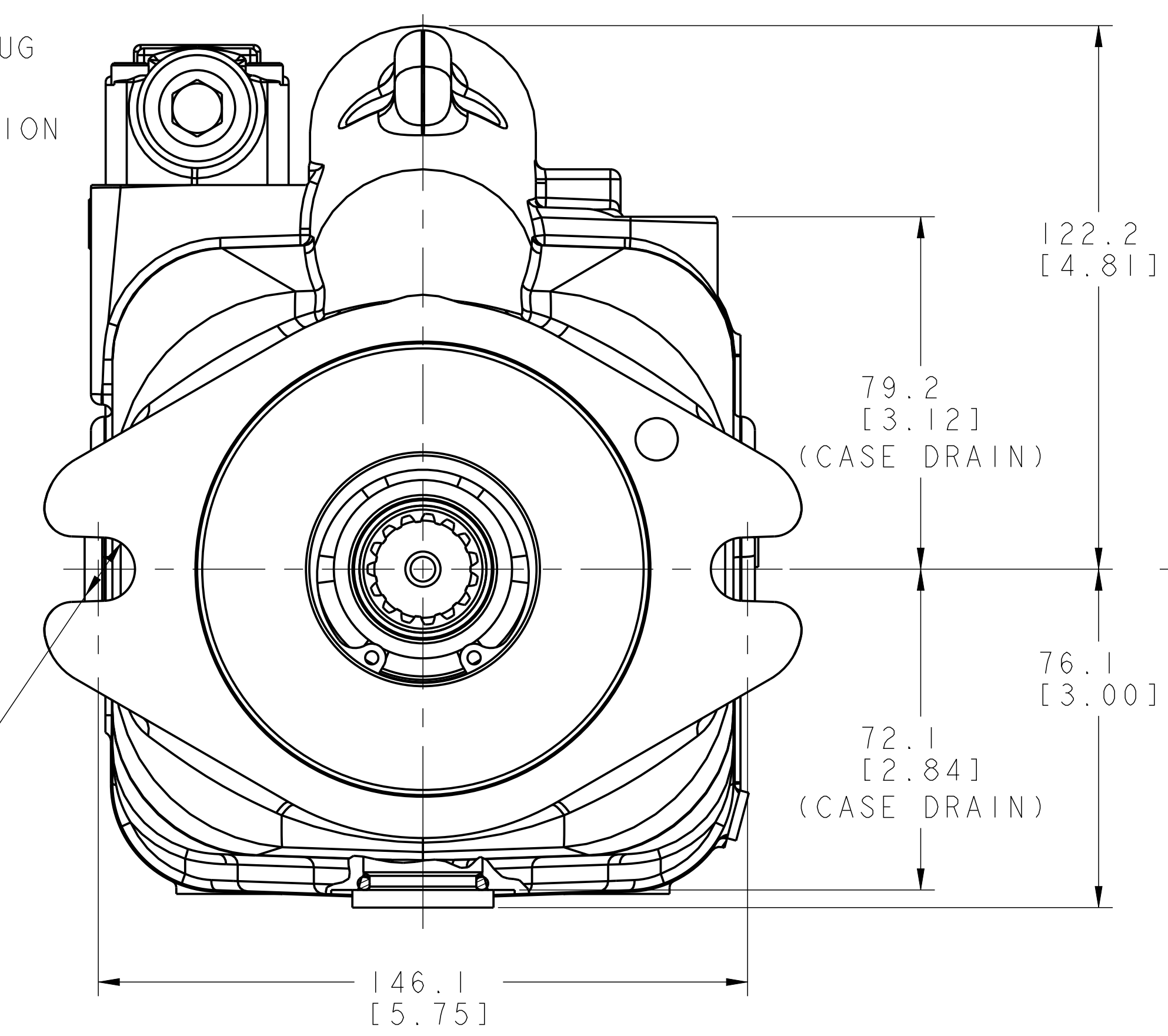
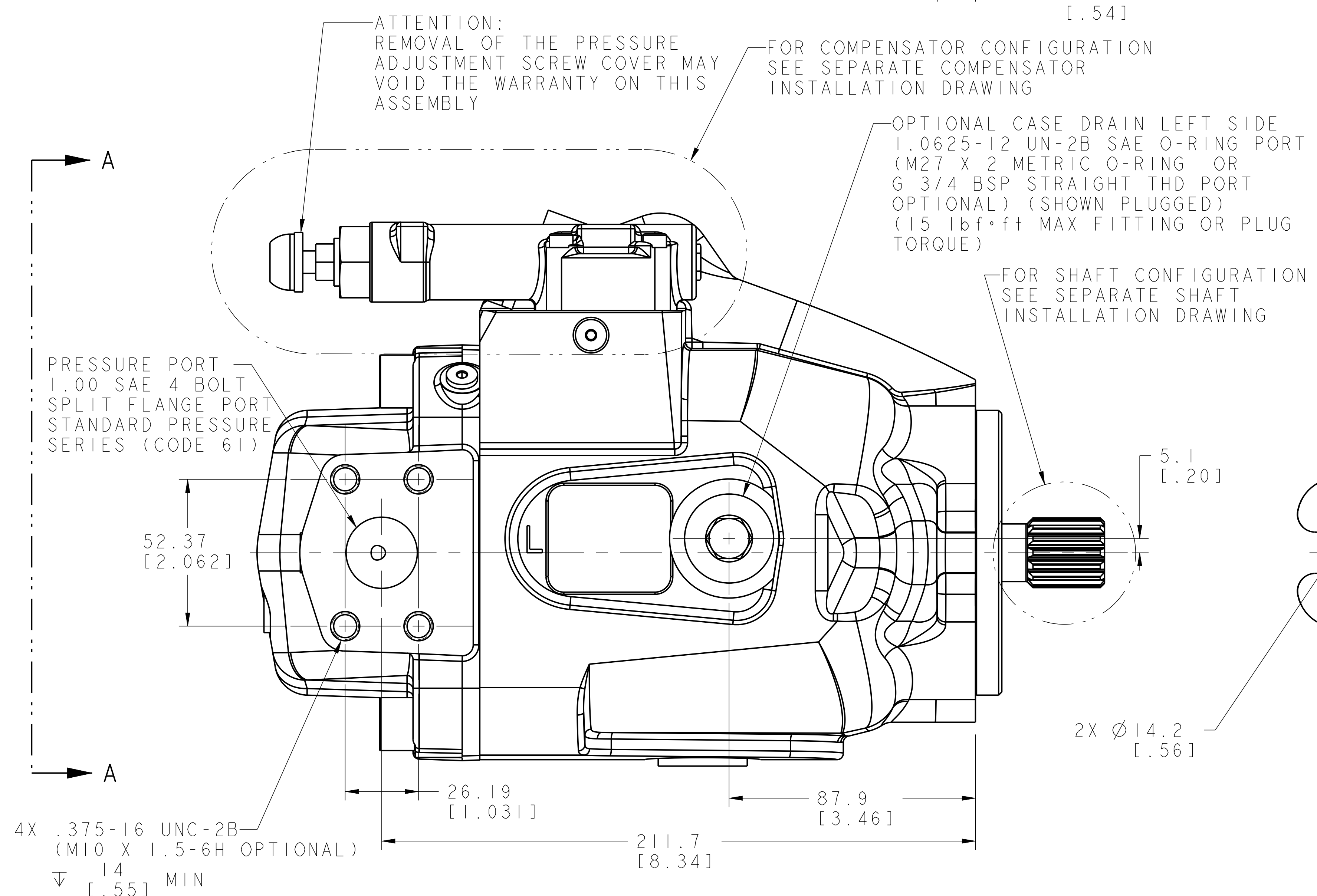
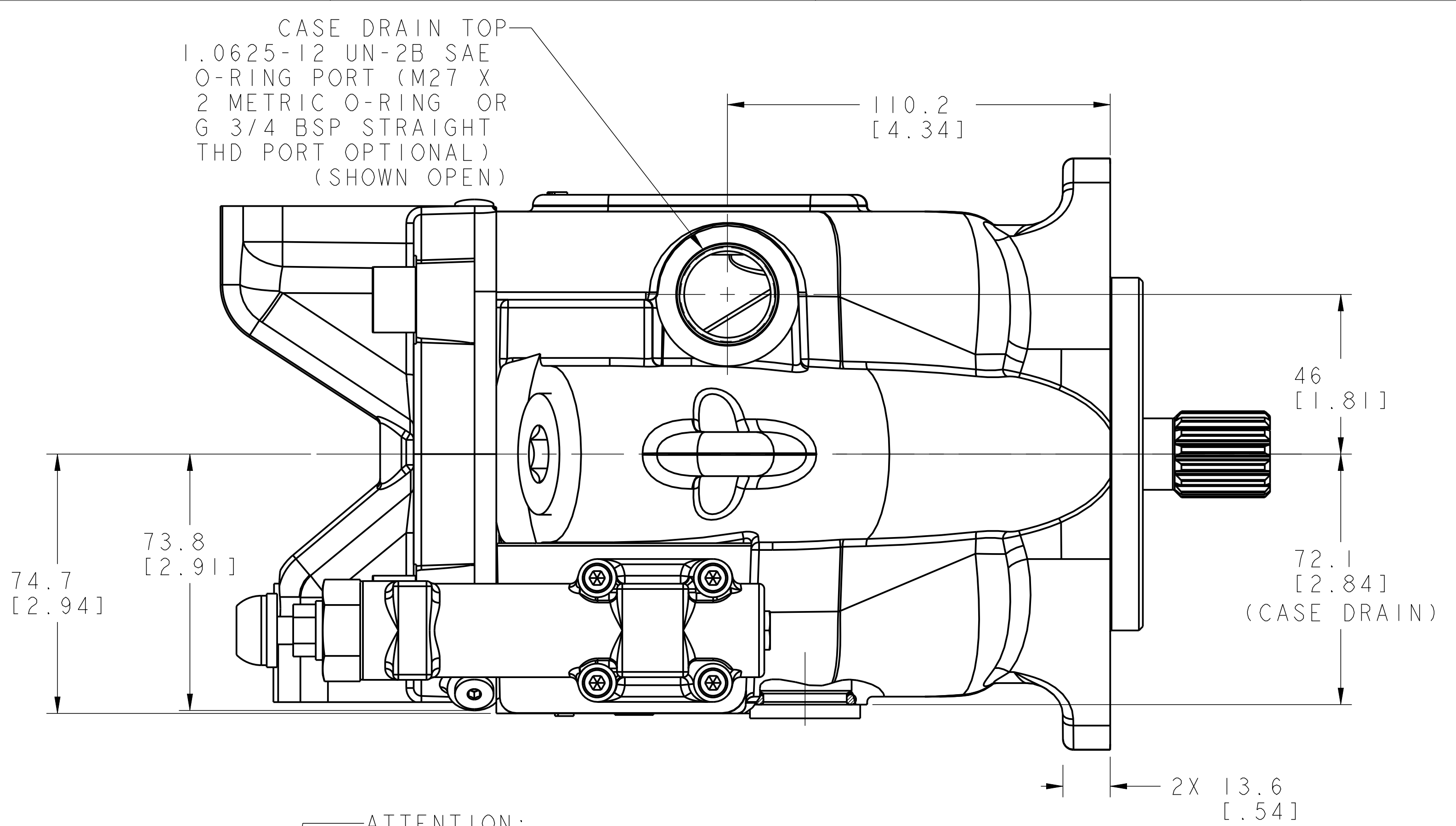

NOTE  
1 UNIT MUST BE INSTALLED IN SUCH A POSITION THAT THE CASE DRAIN ASSURES AN OIL LEVEL AT OR ABOVE UNIT CENTERLINE BEFORE STARTING

REVIEWED FOR CLASSIFICATION PER ESP-042

DRAWING BASED ON ANSI Y14.5M-1982

NOTICE TO PERSONS RECEIVING THIS DRAWING AND / OR TECHNICAL INFORMATION

Eaton Corporation claims proprietary rights in the information disclosed herein. This document is issued in confidence and is not to be reproduced or used to manufacture anything shown herein without the written permission of the Eaton Corporation.

Eaton Hydraulics, Inc.  
14615 Lone Oak Road  
Eden Prairie, Mn, 55344

UNLESS OTHERWISE SPECIFIED ALL DIMENSIONS ARE IN INCHES [MILLIMETERS (INCHES)]	TOLERANCES .x ± .0005 .xx ± REF .xxx ± ONLY < ± .0005	UNSPECIFIED RADII ARE: ---	UNSPECIFIED DRAFT ANGLES ARE: ---	THIRD ANGLE PROJECTION DO NOT SCALE	ARITHMETICAL AVERAGE	NUMBER A-3216-004	SCALE 1/1	SHEET 1 OF 1
DRAWN NWS BY/DATE 12-27-07	CHECKED BMS BY/DATE 12-27-07	ENGRG DJZ BY/DATE 12-27-07	METALLURGY BY/DATE ---	MATERIAL/HEAT TREAT		TITLE SERIES 420 PUMP INSTALLATION		