

| REV | DESCRIPTION             | BY  | CHK | DATE    | ECN    |
|-----|-------------------------|-----|-----|---------|--------|
| A   | ENGINEERING RELEASE     | CAD | CMJ | 4/8/92  | 21480  |
| B   | 22.4[.88] WAS 22.2[.88] | JLY | MLL | 4/14/97 | M17240 |
|     |                         |     |     |         |        |

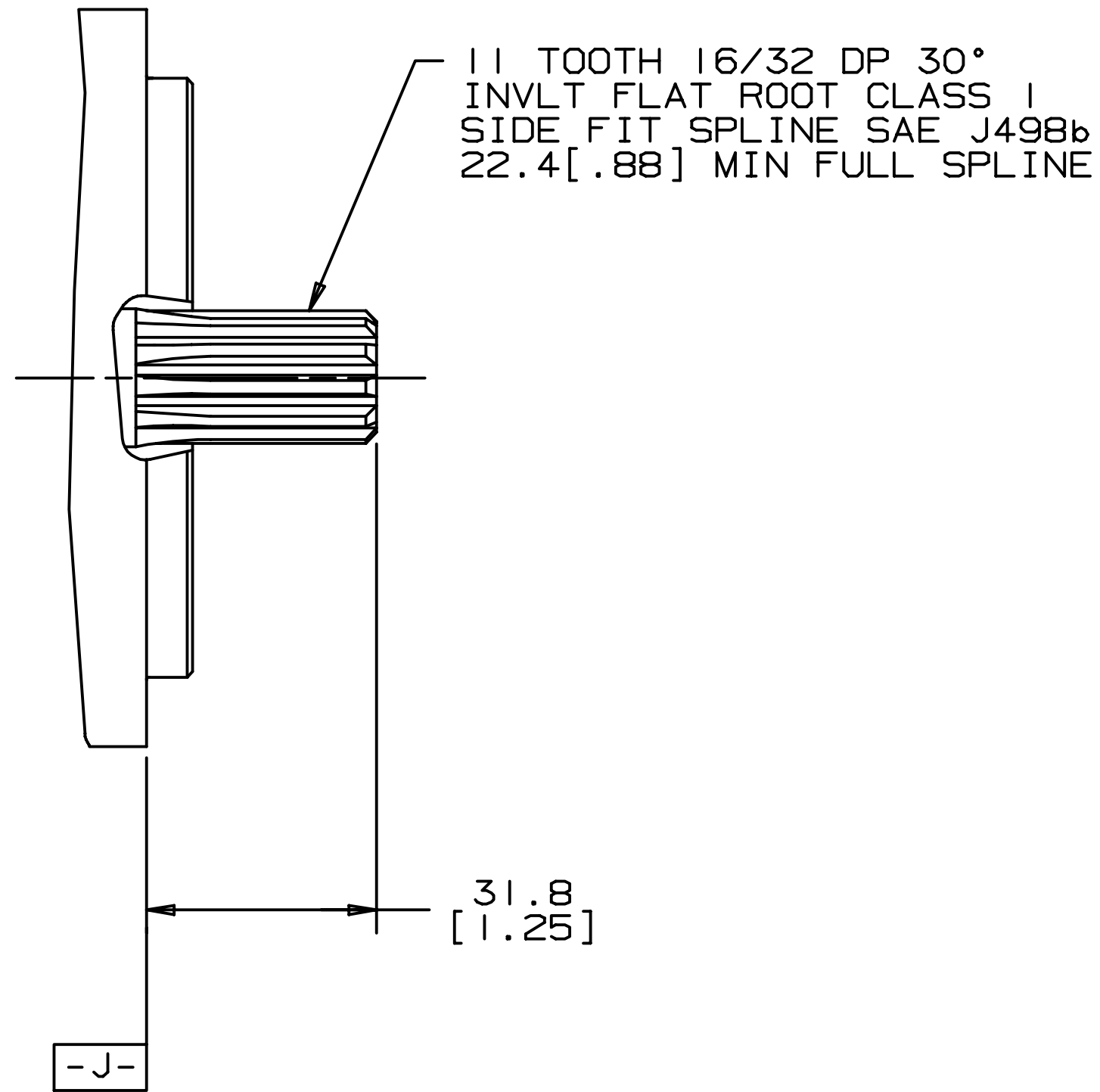

GH

|  |   |   |
|--|---|---|
| UNLESS OTHERWISE SPECIFIED ALL DIMENSIONS ARE IN<br>INCHES <input type="checkbox"/><br>MILLIMETERS <input checked="" type="checkbox"/> | DRAWING BASED ON ANSI Y14.5M-1982   |   |
|  | NOTICE TO PERSONS RECEIVING THIS DRAWING AND / OR TECHNICAL INFORMATION<br>Eaton Corporation claims proprietary rights in the information disclosed hereon. This document is issued in confidence and is not to be reproduced or used to manufacture anything shown hereon without the written permission of the Eaton Corporation. |   |
| TOLERANCES<br>.X ±----<br>.XX ±REF<br>.XXX ±ONLY<br>< ±----  | DRAWN C DOTY<br>BY/DATE 10/22/91  | MATERIAL/HEAT TREAT<br><br>TITLE<br>SHAFT INSTALLATION  |
|  | CHECKED CMJ 5/15/92<br>BY/DATE  |   |
| UNSPECIFIED RADII ARE<br>-----   | ENGRG JCW 6/29/92<br>BY/DATE  | MICROINCHES <input type="checkbox"/><br>MICROMETERS <input type="checkbox"/><br>[MICROINCHES]<br>ARITHMETICAL AVERAGE <input checked="" type="checkbox"/> |
| UNSPECIFIED DRAFT ANGLES ARE<br>-----  | THIRD ANGLE PROJECTION  |   |
| DRAWING FORMAT<br>CADD <input checked="" type="checkbox"/> MANUAL <input type="checkbox"/>   | DO NOT SCALE  | NUMBER<br>A-349-002<br>SCALE 1/1 SHEET 1 OF 1   |

