

THE REPRODUCTION, DISTRIBUTION AND UTILIZATION OF THIS DOCUMENT AS WELL AS THE COMMUNICATION OF ITS CONTENTS TO OTHERS WITHOUT EXPLICIT AUTHORIZATION IS PROHIBITED. OFFENDERS WILL BE HELD LIABLE FOR THE PAYMENT OF DAMAGES. ALL RIGHT RESERVED IN THE EVENT OF THE GRANT OF A PATENT, UTILITY MODEL OR DESIGN. (PER ISO 18018)

REVISIONS

| REV | DESCRIPTION | DATE | APPROVED |
|-----|--|---------|--------------------|
| A | REDRAWN - SUPERSEDES 1GA_FS_ REV. "NONE" FOR 1GA6FS6 (1)NOTE # 1(a) WAS: "CRIMP NUT PER ACES 2813" | 3-17-95 | EN-F15566 DP-24900 |

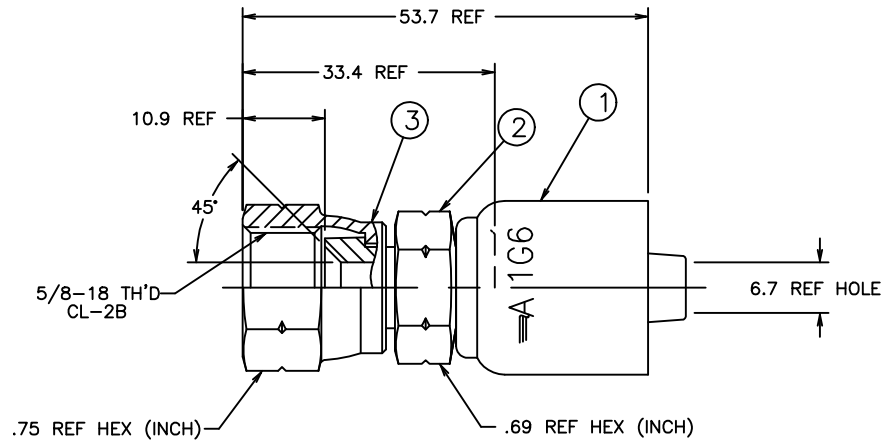

| | |
|------|------|
| 53.7 | 2.11 |
| 33.4 | 1.31 |
| 10.9 | .43 |
| 6.7 | .26 |
| MM | INCH |

CONVERSION

METRIC

| 1GA6FS6 | 1G6 | 1F40001A0606-S | 210224-6S |
|----------------------|----------|----------------------|------------------------|
| AEROQUIP PART NUMBER | ① SOCKET | ② NIPPLE | ③ NUT |
| LIST OF MATERIALS | | | |
| ITEM NO. | MATERIAL | DRAWN J. HUFFMAN | |
| 1 | STEEL | CHECKED R. GARRETT | |
| 2 | STEEL | APPROVED R. GARRETT | |
| 3 | STEEL | RELEASE DATE 3-20-95 | |
| | | EN-F15566 DP-24900 | |
| | | SIZE C | DRAWING NUMBER 1GA6FS6 |
| | | SCALE 2/1 | DIST U |
| | | CAGE CODE 01276 | SHEET NO |

2. 1SA6FS6 NIPPLE ASSEMBLY MAY BE SUBSTITUTED FOR ITEMS #2 AND #3.

1. PROCESS AS FOLLOWS:
 (a) CRIMP NUT PER ACES 2409P3.
 (b) ASSEMBLE SOCKET PER ACES 2813. ①

DWG. NO. 1GA6FS6 SH. REV. A

CONVERTED DRAWING CADAM to AutoCAD 8/98