

REV	DESCRIPTION	BY	CHK	DATE	ECN / MPS
A	ENGINEERING RELEASE	RSI	JGS	2/12/05	M63978

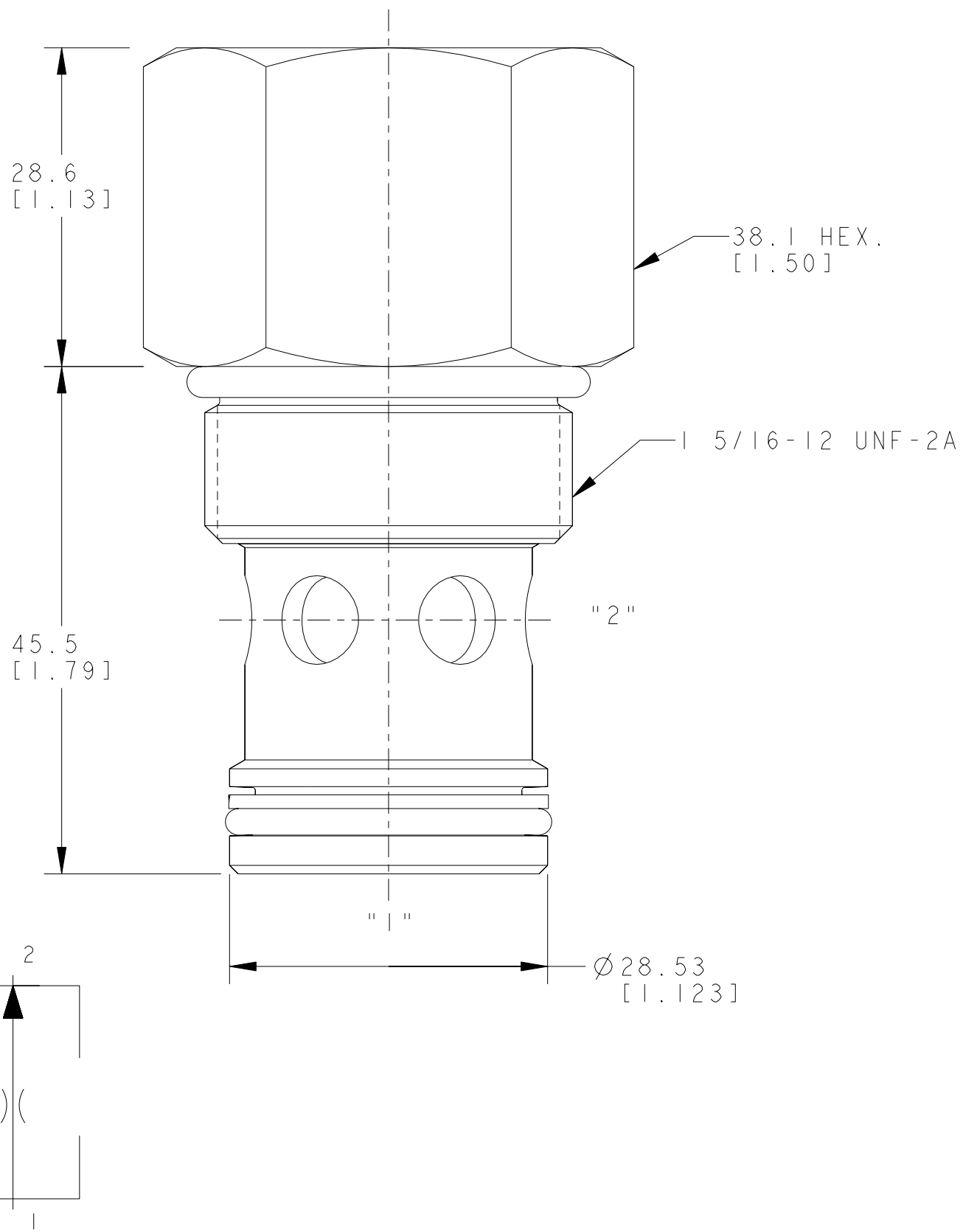

NOTE:
 1. USE VALVE CAVITY C-16-2.
 2. NET WEIGHT: 0.33kg [.72 lb]
 3. TORQUE INTO CAVITY:
 ALUMINIUM CAVITY: 108-122 N.m [80-90 lbf.ft]
 STEEL CAVITY : 136-149 N.m [100-110 lbf.ft]

 DISTRIBUTION CODE(S)

UNLESS OTHERWISE SPECIFIED ALL DIMENSIONS ARE IN INCHES <input type="checkbox"/> MILLIMETERS (INCHES) <input checked="" type="checkbox"/>	DRAWING BASED ON ANSI Y14.5M-1982	
	THE REPRODUCTION, DISTRIBUTION, AND UTILIZATION OF THIS DOCUMENT, AS WELL AS THE COMMUNICATION OF ITS CONTENTS TO OTHERS WITHOUT EXPLICIT AUTHORIZATION IS PROHIBITED. OFFENDERS WILL BE HELD LIABLE FOR THE PAYMENT OF DAMAGES. ALL RIGHTS RESERVED IN THE EVENT OF THE GRANT OF A PATENT, UTILITY MODEL, OR DESIGN. (PER ISO 16016)	
TOLERANCES .X ± -- .XX ± -- .XXX ± -- < ± --	DRAWN RS BY/DATE 04/01/05	MATERIAL --
	CHECKED RSI BY/DATE 04/13/05	
UNSPECIFIED RADII ARE: --	ENGRG -- BY/DATE	TITLE
	METALLURGY -- BY/DATE	FRI-16 INSTALLATION
UNSPECIFIED DRAFT ANGLES ARE: --°	THIRD ANGLE PROJECTION	NUMBER A-2668-003
	B SIZE	
	DO NOT SCALE	SHEET 1 OF 1

